

**VILLAGE OF NEW GLARUS - VILLAGE BOARD PROCEEDINGS REGULAR MEETING**

Village Hall Board Room

319 2<sup>nd</sup> Street New Glarus, WI

Zoom Meeting Link: <https://us02web.zoom.us/j/86282679978>

5/16/2023

7:00 P.M.

<b>7:00 P.M. Regular Meeting</b>	<b>Page #</b>
1. Call to Order – Please Silence All Cell Phones	
2. Approval of agenda	
3. Public appearances and citizen comments on items not listed on this agenda. [Items will not be debated or acted upon at this meeting but will be referred to the proper staff/committee if action is required.] – <i>Please keep comments to 3 minutes</i>	
4. Approval of Consent Agenda	
A. Approval of Minutes of 4.6.23 Regular Meeting	5
B. Approval of Claims	6
C. April 2023 Building Inspection Report	12
D. April 2023 Police Report	14
5. New Business	
A. Presentation: WPPI Energy Presentation on Rates & Financial Planning	
B. Consideration/Discussion: Special Event Permit - Blues, Brews & Food Trucks, June 24, 2023	16
C. Consideration/Discussion: Operator License for Jolene Klarer	
D. Consideration/Discussion: 2024 Budget Proposed Timeline & Procedures	21
E. Consideration/Discussion: Ordinance 23-03 to Repeal and Recreate Section 269-2 of the Municipal Code of the Village of New Glarus Hotel-Motel Room Tax	22
F. Consideration/Discussion: Resolution 23-15 Appointing Limited Term Employee Public Works Laborer	23
G. Consideration/Discussion: Resolution 23-16 Appointing Limited Term Employee Parks and Recreation Laborer	24
H. Consideration/Discussion: Resolution 23-17 to Appoint Lifeguards, Water Safety Instructors, and Field Supervisor	25
I. Consideration/Discussion: Reschedule July 4 Village Board Meeting	
6. Parks and Recreation	
A. Consideration/Discussion: Charging Station at Village Park	27
7. Public Works and Safety	
A. Consideration/Discussion: Ordinance 23-04 to Strike Section 288-21 (H) of the Municipal Code of the Village New Glarus Parking Regulations	31
B. Consideration/Discussion: Special Assessments for 3 <sup>rd</sup> Avenue between 3 <sup>rd</sup> Street & 8 <sup>th</sup> Street	32
C. Consideration/Discussion: Qualifications-Based Selection of Engineer for Water Reservoir	36
D. Consideration/Discussion: Water Reservoir Tank Option Selection	42
8. Personnel and Finance	
9. President's Report	
A. Friends of the Chalet of the Golden Fleece 10 <sup>th</sup> Anniversary Proclamation	44
B. Committee Appointments	45
10. Announcement: The Village Board Will Adjourn into Closed Session Pursuant to Wisconsin State Statute 19.85(1) (c): Deliberating or negotiating the investing of public funds, or conducting other specified public business, whenever competitive or bargaining reasons require a closed session and considering employment, promotion, compensation or performance evaluation data of any public employee over which the governmental body has jurisdiction or exercises responsibility require a closed session and may reconvene to open session pursuant to State Statute 19.85 (1) (Employee Compensation Matters)	
11. The Board may take action of any matter as a result of the closed session	
12. Adjournment	1

Roger Truttmann, President

AGENDA POSTED: N.G. Village Hall 5/12/23  
N.G. Post Office 5/12/23  
Bank of New Glarus 5/12/23

Kelsey Jenson, Clerk

PERSONS REQUIRING ADDITIONAL SERVICES TO PARTICIPATE IN A PUBLIC MEETING MAY CONTACT  
THE VILLAGE CLERK FOR ASSISTANCE AT 527-2510

## Village Board Meeting Notes

May 16, 2023

### **Consent Agenda:**

Approval of Minutes of 5/3 Regular meeting: The minutes are included in the packet for consideration.

Approval of Claims: The claims lists are included in your packet and include: ACH for payroll expenses, health insurance, April credit card; e-check for life insurance; journal entry for utility bill - totaling \$66000.60; payroll vouchers 17216 to 17239 totaling \$30202.42; and checks 41983 to 42031 totaling \$139,339.67.

April 2023 Building Inspection Report: The report is included in the packet for consideration.

April 2023 Police Report: The report is included in the packet for consideration.

### **New Business:**

Presentation: WPPI Energy Presentation on Rates & Financial Planning: Tim Ament from WPPI Energy will give a presentation to the Village Board.

Consideration/Discussion: Special Event Permit – Blues, Brews, & Food Trucks, June 24, 2023: The application has been reviewed by staff and recommended for approval by the Public Works/Public Safety Committee at their May 8, 2023 meeting.

Consideration/Discussion: Operator License for Jolene Klarer: The application has been reviewed by staff and recommended for approval by the Public Works/Public Safety Committee at their May 8, 2023 meeting.

Consideration/Discussion: 2024 Budget Proposed Timeline & Procedures: A memo is included in the agenda packet, which outlines the proposed timeline for the 2024 budget creation and approval process. Staff recommend approval of the proposed timeline and procedures.

Consideration/Discussion: Ordinance 23-03 to Repeal and Recreate Section 269-2 of the Municipal Code of the Village of New Glarus, Hotel-Motel Room Tax: The Tourism Commission met on April 26, 2023 and reviewed the use of room tax funds over the last few years. The Commission voted to recommend adjusting the share of room tax funds to provide additional funding to the Village to cover administrative costs. This does not change the room tax charged to hotels/motels, which is currently set at 5%. This ordinance would change the share of the room tax revenue from 90% Chamber & 7% Village to 85% Chamber & 12% Village. Staff recommend approving the ordinance.

Consideration/Discussion: Resolution 23-15 Appointing Limited Term Employee Public Works Laborer: This resolution approves the re-hire of the summer Public Works LTE. Staff recommend approving the resolution.

Consideration/Discussion: Resolution 23-16 Appointing Limited Term Employee Parks & Recreation Laborer: This resolution approves the hire of the summer Parks & Recreation LTE. Staff recommend approving the resolution.

Consideration/Discussion: Resolution 23-17 to Appoint Lifeguards, Water Safety Instructors, and Field Supervisor: This resolution approves the hire of the 2023 season pool staff. Staff recommend approving the resolution.

Consideration/Discussion: Reschedule July 4 Village Board Meeting: The first meeting in July will fall on the Fourth of July holiday.

**Parks and Recreation:**

Consideration/Discussion: Charging Station at Village Park: The Library submitted a proposal to install a charging pole and bench in Village Park. A memo with more information is included in the packet. Staff recommend approving the planned location for the charging station.

**Public Works and Safety:**

Consideration/Discussion: Ordinance 23-04 to Strike Section 288-21 (H) of the Municipal Code of the Village New Glarus Parking Regulations: This ordinance would allow staff to remove “No Parking” signs on 4<sup>th</sup> Avenue next to Glarner Park. The removal of these signs was recommended by the Public Works/Public Safety Committee at their April 10, 2023 meeting. Staff recommend approving the ordinance.

Consideration/Discussion: Special Assessments for 3<sup>rd</sup> Avenue between 3<sup>rd</sup> Street & 8<sup>th</sup> Street: The Public Works/Public Safety Committee held a Public Hearing for the preliminary special assessments for the 3<sup>rd</sup> Avenue project. The special assessments will be finalized after the project has been completed. The Public Works/Public Safety Committee recommended approval at their May 8, 2023 meeting. Staff recommend approving the special assessments for 3<sup>rd</sup> Avenue between 3<sup>rd</sup> & 8<sup>th</sup> Street.

Consideration/Discussion: Qualifications-Based Selection of Engineer for Water Reservoir: Staff put out a Request for Statement of Qualifications for firms interested in providing engineering for the water reservoir project. The Village received two submittals, Strand Engineering and Town & Country. Staff recommend moving forward with Town & Country given their knowledge and experience with the Village of New Glarus as the current water engineer. The Public Works/Public Safety Committee recommended selecting Town & Country at their May 8, 2023 meeting.

Consideration/Discussion: Water Reservoir Tank Option Selection: Town & Country provided several options for the water reservoir tank; their memo is included in the agenda packet. After reviewing options, staff recommend moving forward with the prestressed concrete tank. The Public Works/Public Safety Committee recommended selecting the prestressed concrete tank option at their May 8, 2023 meeting.

**President’s Report:**

Friends of the Chalet of the Golden Fleece 10<sup>th</sup> Anniversary Proclamation: A proclamation honoring the Friends of the Chalet is included in the agenda packet. Trustee Larry Stuessy will read the proclamation.

Committee Appointments: An updated committee appointments list is included in the agenda packet.

VILLAGE BOARD PROCEEDINGS  
VILLAGE OF NEW GLARUS  
5/3/23

REGULAR MEETING-CALL TO ORDER: President Truttman called the regular meeting to order at 7:00 p.m.

PRESENT: Chuck Phillipson, Michael Bell, Mike Marty, Larry Stuessy, Peggy Kruse and Roger Truttman.

ALSO PRESENT: Gof Thomson, Amy Trumble (Library Director), Joe Cockroft (Public Works Director), Lauren Freeman (Village Administrator), Chief Jeff Sturdevant (Police Chief), Kelsey Jenson (Clerk-Treasurer)

APPROVAL OF AGENDA: Motion by Peggy, second by Michael Bell, to approve the 5/3/23 agenda. Motion carried (6-0).

PUBLIC APPEARANCES AND CITIZEN COMMENTS: None.

CONSENT AGENDA: Motion by Mike Marty for approval of the consent agenda, second by Michael Bell. Motion carried (6-0).

APPROVAL OF MINUTES OF 4/18/23 Regular Meeting

APPROVAL OF CLAIMS: The claims lists were presented to the Board and include: ACH for payroll expenses, retirement, and wire for monthly power bill - totaling \$166,564.08; payroll vouchers 17174 to 17215 totaling \$40,617.03; and checks 41951 to 41982 totaling \$135,536.86.

NEW BUSINESS

Consideration/Discussion: Village Board Trustee Appointment:

Motion by Larry Stuessy to appoint Gof Thomson to the vacant Village Board position, second by Chuck Phillipson. Motion carried (6-0).

Consideration/Discussion: Resolution 23-12 for Appointment of Full Time Journey Lineworker:

Motion by Chuck Phillipson to approve R23-12 for the appointment of the full time journey lineworker, second by Mike Marty. Motion carried (7-0).

Consideration/Discussion: Façade Improvement Grant Budget & Award Maximum:

Motion by Larry Stuessy to approve the proposed increases to \$6,000 and \$40,000 maximums, second by Peggy Kruse. Motion carried (7-0).

Consideration/Discussion: Façade Improvement Grant Application for 500 1<sup>st</sup> St:

Motion by Michael Bell to approve Façade Improvement Grant application for 500 1<sup>st</sup> St, second by Mike Marty. Motion carried (7-0).

Consideration/Discussion: Façade Improvement Grant Application for 17 6<sup>th</sup> Ave:

Motion by Michael Bell to approve Façade Improvement Grant application for 17 6<sup>th</sup> Ave, second by Peggy Kruse. Motion carried (7-0).

Consideration/Discussion: Façade Improvement Grant Application for 18 7<sup>th</sup> Ave:

Motion by Peggy Kruse to approve Façade Improvement Grant application for 18 7<sup>th</sup> Ave, second by Michael Bell. Motion carried (7-0).

Consideration/Discussion: Resolution 23-14 Adopting the Updated Green County Hazard Mitigation Plan:

Motion by Peggy Kruse to approve R23-14 adopting the updated Green County Hazard Mitigation Plan, second by Larry Stuessy. Motion carried (7-0).

PARKS AND RECREATION

Trustee Marty informed the Board that the grant for Candy Cane Park was submitted. They can expect to hear if the Village received the grant in late summer/early fall.

PUBLIC WORKS AND SAFETY

PW Director Cockroft shared details of the successful culvert reconstruction on Hwy 69.

PERSONNEL AND FINANCE

Consideration/Discussion: Consideration/Discussion: Resolution 23-13 for Wage Increases for Line Foreman, Journey Lineworker, and Water Operator:

Motion by Chuck Phillipson to approve R23-13 for wage increases for line foreman, journey lineworker and water operator, second by Mike Marty. Motion carried (7-0).

PRESIDENT'S REPORT

President Truttman reminded the Board of the Administrator/Department Head Meet & Greet on Tuesday, May 9. He also confirmed that newly appointed Trustee Thomson will serve on the Public Works/Public Safety Committee and the New Glarus Fire District Board. Committee appointments will be presented for approval at the May 16 Board meeting.

CLOSED SESSION

Motion by Peggy Kruse, seconded by Michael Bell and roll call vote 7-0 to adjourn into Closed Session Pursuant to Wisconsin State Statute 19.85(1)(e) and (g): Deliberating or negotiating the purchasing of public properties, the investing of public funds, or conducting other specified public business, whenever competitive or bargaining reasons require a closed session and conferring with legal counsel for the governmental body who is rendering oral or written advice concerning strategy to be adopted by the body with respect to litigation in which it is or is likely to become involved. [Genthe Easement].

Motion by Peggy Kruse to reconvene to open session, seconded by Michael Bell and roll call vote 7-0. The Village Board then adjourned into open session.

ADJOURN: Being no further business, President Truttmann adjourned the meeting at 8:08 p.m.

– Kelsey Jenson,  
Clerk-Treasurer

*\*For more details on agenda items, please visit [newglarusvillage.com](http://newglarusvillage.com) to view the meeting agenda packet. A recording of the meeting is also available on the Village of New Glarus YouTube Channel.*

Report Criteria:

Report type: Summary

Check.Check Issue Date = 05/17/2023

GL Period	Check Issue Date	Check Number	Vendor Number	Payee	Amount
05/23	05/17/2023	41983	1120	ARAMARK UNIFORM SERVICES	364.33
05/23	05/17/2023	41984	6121	AUTO VALUE NEW GLARUS	680.54
05/23	05/17/2023	41985	5826	AXON ENTERPRISE INC.	14,582.16
05/23	05/17/2023	41986	4459	B & M TECHNICAL SERVICES	1,210.00
05/23	05/17/2023	41987	3961	BADGER SWIMPOOLS INC.	16,212.40
05/23	05/17/2023	41988	1165	BAKER & TAYLOR BOOKS	447.98
05/23	05/17/2023	41989	1250	BLACKHAWK TECH COLLEGE	20.00
05/23	05/17/2023	41990	1255	BLANCHARDVILLE CO-OP	1,539.48
05/23	05/17/2023	41991	1275	BORDER STATES ELECTRIC SUP	2,523.77
05/23	05/17/2023	41992	4078	CLARK ELECTRIC	589.70
05/23	05/17/2023	41993	5842	CLASSY CLEANERS	1,235.00
05/23	05/17/2023	41994	5605	COAST TO COAST	140.20
05/23	05/17/2023	41995	4179	COPLIEN PAINTING INC	13,574.00
05/23	05/17/2023	41996	1555	CULLIGAN WATER CONDITIONING IN	46.00
05/23	05/17/2023	41997	4039	GENERAL CODE, LLC	695.00
05/23	05/17/2023	41998	5731	GREEN COUNTY EMERGENCY MANA	6.00
05/23	05/17/2023	41999	6213	HART, COREY	100.00
05/23	05/17/2023	42000	5930	HYDROCORP	345.00
05/23	05/17/2023	42001	5166	KIMBALL MIDWEST	196.47
05/23	05/17/2023	42002	2320	L.V. LABS WW LLC	1,541.50
05/23	05/17/2023	42003	6042	LIFTOFF LLC	816.00
05/23	05/17/2023	42004	5919	M&D TRUCK AND EQUIPMENT SALES	1,760.00
05/23	05/17/2023	42005	5286	MDROFFERS CONSULTING LLC	411.60
05/23	05/17/2023	42006	2515	MIDWEST TAPE	187.42
05/23	05/17/2023	42007	6243	MONARCH MEDIA DESIGNS LLC	365.85
05/23	05/17/2023	42008	4316	MURPHY DESMOND S.C.	1,532.75
05/23	05/17/2023	42009	2695	NEW GLARUS CHAMBER OF COMME	12,683.00
05/23	05/17/2023	42010	4073	NEW GLARUS CONCRETE	3,963.00
05/23	05/17/2023	42011	4754	NEW GLARUS HARDWARE	152.11
05/23	05/17/2023	42012	2730	NEW GLARUS POLICE ASSOC	10.00
05/23	05/17/2023	42013	2745	NEWS PUBLISHING COMPANY	294.32
05/23	05/17/2023	42014	5828	NORTHWOODS	191.43
05/23	05/17/2023	42015	5981	SABEL MECHANICAL LLC	5,168.88
05/23	05/17/2023	42016	3120	SCHOOL DIST OF NEW GLARUS	368.53
05/23	05/17/2023	42017	4043	SEAMLESS GUTTERS UNLMTED LLC	120.00
05/23	05/17/2023	42018	5201	SEERA	880.29
05/23	05/17/2023	42019	6122	SHERWIN INDUSTRIES INC	1,092.00
05/23	05/17/2023	42020	2490	SLOAN IMPLEMENT	21.72
05/23	05/17/2023	42021	3210	SPEE-DEE DELIVERY SERVICE INC	218.69
05/23	05/17/2023	42022	6242	SSM HEALTH MEDICAL GROUP	2,007.00
05/23	05/17/2023	42023	3250	STRAND ASSOCIATES INC	37,728.73
05/23	05/17/2023	42024	5691	SULLIVAN LANDSCAPING	585.00
05/23	05/17/2023	42025	5963	TOP PACK DEFENSE LLC	65.15
05/23	05/17/2023	42026	5285	TOTAL INSPECTION SERVICES LLC	8,666.90
05/23	05/17/2023	42027	3440	TRUGREEN PROCESSING CENTER	338.33
05/23	05/17/2023	42028	3480	UNITED STATES CELLULAR	156.81
05/23	05/17/2023	42029	3991	WE ENERGIES	3,390.63
05/23	05/17/2023	42030	3805	WI PROF POLICE ASSN	86.00
05/23	05/17/2023	42031	3230	WI STATE LAB OF HYGIENE	28.00

M = Manual Check, V = Void Check





Report Criteria:

Check.Check Issue Date = 05/17/2023

---

<u>GL Invoice Acct</u>	<u>Amt</u>
Total 10:	66,526.84
Total 11:	12,683.00
Total 22:	808.50
Total 25:	735.40
Total 30:	70.34
Total 40:	46,741.47
Total 45:	15.66
Total 50:	11,683.13
Total 60:	68.80
Total 70:	6.53
Grand Totals:	<u>139,339.67</u>

---

**VILLAGE OF NEW GLARUS-CLAIMS PRESENTED -**

**5/16/2023**

CHECK #	PAYEE	DIST.	AMOUNT
ACH	941 Tax	payroll	9,732.94
ACH	WI Withholding	payroll	1,650.12
ACH	Great-West Retirement	deferred comp-pre tax	701.00
ACH	Great-West Retirement	deferred comp-post tax	150.00
e-check	Securian	life insurance	515.45
JE	New Glarus Utilites	utility bill	11,457.59
ACH	ETF	health insurance	26,950.26
ACH	US Bank	April credit card	14,843.24
	<b>Sub-total</b>		<b>66,000.60</b>

**Payroll - paid 5/5/2023**

17216	Kelsey Jenson	Clerk	1,700.19
17217	Deanna Young	Deputy Clerk	1,338.90
17218	Lauren Freeman	Administrator	2,146.13
7219	Mark Binger	PD	1,097.83
17220	Chanse Kaczmariski	PD	460.01
17221	Alex Brey	PD	1,647.76
17222	Hunter Krohn	PD	1,943.63
17223	Jeff Sturdevant	PD	2,186.19
17224	Molly Hultine	PD	323.06
17225	Ann Lahey	PD	643.79
17226	Joe Cockroft	PW	2,048.27
17227	Charles Loeffelholz	PW	1,440.18
17228	Kenneth Wolfe	PW	1,088.10
17229	Aaron Funseth	Water Treatment Plant	2,140.90
17230	Jason Borth	Utility	2,398.74
17231	Kevin Funseth	Utility	2,411.88
17232	Beth Heller	Utility	1,202.82
17233	Erica Loeffelholtz	Library	1,044.38
17234	Peggy Hammerly	Library	97.96
17235	Brooke Mathews	Library	942.85
17236	Alayna Lewis	Library	65.31
17237	Amy Trumble	Library	1,256.11
17238	Julie Hawkins	Library	446.81
17239	Amalia Morrison	Library	130.62
	<b>Payroll Subtotal</b>		<b>30,202.42</b>

**Village of New Glarus  
Building Inspection Summary  
April, 2023**

**Project: 2300**  
**Municipality Code:**

DATE	PERMIT #	OWNER	ADDRESS	JOB TYPE	COST	CONTRACTOR	FEE
4-6-23	230023-19	Gary Bennet	400 3rd ave	HVAC	\$10638	Monroe Heating	\$50
4-6-23	230023-20	Mark Hammes	144 valle Tell	H2O	\$850	Dave Jones	\$50
4-6-23	230023-21	Kenny Ramm	100 11th Ave	HVAC	\$11,059	Monroe Heating	\$100
4-13-23	230023-22	Joanne Landry	201 2nd St	Shed zoning		Owner	\$25
4-13-23	230023-23	Ester Zgragen	10 Kubly Rd	Solar	\$12,054	Everlight	\$115
4-13-23	230023-24	Edelwess apt	300 Elmer Rd	Signs	\$2400	Vital Signs	\$50
4-13-23	230023-25	Edelweiss Apt	301 5th St	Sign	\$2400	Vital Signs	\$50
4-13-23	230023-26	Pat Nevil	501 12th Ave	Reroof	\$12,700	Seamless	\$50
4-13-23	230023-27	Dan Carlson	807 3rd Ave	Chicken coop		owner	\$25
4-17-23	230023-28	Jill Starz	307 8th St	Fence	\$7800	Brothers Fence	\$25
4-20-23	230023-29	New Glarus Schools	1701 2nd St	Remodel	\$3,347,000	Kraemer	\$8,691.77
4-20-23	230023-30	New Glarus Schools	1420 2nd St1	Remo	\$210,000	Kraemer	\$434.24
4-20-23	230023-31	Mark Malin	842 10th Ave	Zoning shed	\$5000	owner	\$25
4-20-23	230023-32	Scott Hook	506 1st St	sign	\$1500	Owner	\$50

--	--	--	--	--	--	--	--

May 2, 2023

To: Administrator Freeman and the New Glarus Public Safety/Works Committee

From: Chief Jeff Sturdevant

Reference: April Monthly Police Report

Here is the summary of the Police Department statistics for last month and the year to date calls for service along with a comparative to last year's numbers.

<b>Types of Calls</b>	<b>Current Month</b>	<b>Since Jan 1st</b>	<b>Total Last Year</b>
<b>Overall calls for service</b>	331	1325	3791
<b>Assist other agencies/departments</b>	30	123	528
<b>Incarcerated/Jailed</b>	2	12	44
<b>Traffic/Municipal Citations</b>	50	167	618
<b>Traffic Warnings</b>	67	266	738
<b>Parking Citations</b>	4	129	258
<b>Traffic Accidents</b>	2	4	42

**Notable information or call(s) for service:**

- The department has been handling an increased call volume in dogs and cats attacking people or other domestic animals and running at large complaints in the Village.
- 04-24-22 The New Glarus Police Department turned over 41.5 pounds of raw prescription medications to the Department of Justice for disposal that are collected in the Drug Drop Box located in the Police Department lobby.

- A Sex Assault investigation that was originally reported to our Department on March 2023, resulted in the offender being charged in Green County Circuit Court for a total of seventeen (17) different criminal charges.

### **Training Attended:**

- On 04-18-23, Chief Sturdevant attended an all-day School Threat Assessment and Mass Casualty Threat Assessment Training sponsored by the United States Secret Service in Madison at the American Family Insurance Complex.
- Firearms Training-The entire department attended a monthly 3-hour firearms and room clearing training that was held at the Blackhawk Technical College campus in Janesville.
- Officer Krohn attended a Severe Weather and Tornado Spotters training that was held at the New Glarus Fire Department sponsored by the National Weather Service. Now the entire department is trained.

### **Grants:**

- I will be discussing some grants that I have completed and received reference purchasing of equipment for the Police Department. The equipment includes:
  - Toughbook 55 Computer for new squad and all equipment for using computer in the new squad car (power supply, docking station, mounts and printer).
  - FirstNet cradle point router
  - Three (3) New digital photograph cameras
  - Two (2) Kustom Eagle III Radar Units for squads

Total Received on Grants: \$13,800.00

### **Hiring Process:**

- I will be giving an update at the meeting reference the current hiring process for the two (2) open full-time positions.



# Village of New Glarus

319 Second Street

PO Box 399

New Glarus WI 53574

(608)527-2510

[www.newglarusvillage.com](http://www.newglarusvillage.com)

---

## [DRAFT] SPECIAL EVENTS PERMIT #23-SE-04 TEMPORARY CLASS "B" LICENSE # 23-T -4

ISSUED TO: New Glarus Chamber of Commerce  
Rebekah Stauffacher

EVENT: **New Glarus Blues, Brews & Food Trucks 2023**

DATES/TIMES: Saturday, June 24<sup>th</sup>, 2023  
Set-up begins 8:00 a.m., Friday June 23, 2023 through Tuesday, June 27, 2023 tear down

### LOCATIONS/USES OF PUBLIC FACILITIES:

1. Closure of 3<sup>rd</sup> Avenue between Railroad St and 2<sup>nd</sup> Street
2. Closure of 4<sup>rd</sup> Avenue between Railroad Street and 2<sup>nd</sup> Street
3. Village Park

### STREET CLOSURES/NO PARKING:

1. Closure of 3<sup>rd</sup> Avenue between Railroad Street and 2<sup>nd</sup> Street [Saturday, June 24<sup>th</sup> from 8 a.m. through 8 a.m. Sunday June 25<sup>th</sup>]
2. Closure of 4<sup>rd</sup> Avenue between Railroad Street and 2<sup>nd</sup> Street [Friday, June 23<sup>rd</sup> 8 a.m. through Tuesday, June 27<sup>th</sup> 4 p.m.]
3. Regular parking stalls changed to musician unloading zone and handicapped parking only – 2<sup>nd</sup> Street between 3<sup>rd</sup> Avenue and 4<sup>th</sup> Avenue, Saturday, June 24<sup>th</sup> 8 a.m. – 11:59 p.m.
4. Three parking stalls at southeast corner of Village Park along Railroad Street –for dumpster, June 20<sup>th</sup> through June 29<sup>th</sup> (dependent on delivery schedule)
5. 12 parking stalls at northwest corner of Village Park along 3<sup>rd</sup> Avenue for bathrooms, Friday June 23<sup>rd</sup> 8 a.m. - Monday, June 26<sup>th</sup> 5 p.m.

There shall be NO PARKING of any vehicles within the permitted/designated road closed festival area once the event begins. This includes, volunteers, band members, vendors [with the exception of food trucks], sound people, etc. Travel to and from the vendor booths and stage area is permitted for loading and unloading of equipment, supplies, etc., prior to the event starting. After initial set up, all vehicles shall be removed from the festival area. Officers will be available to assist during band change outs accessing the back-stage area. Any violators will be ticketed and may be towed. All groups/personnel requiring vehicle access to the fest area shall be advised of this by the event promoter.



**VILLAGE PARK:** Event includes the exclusive use of Village Park, specifically the gazebo and grass on the west half of the park with setup on Friday, June 23, 2022 starting at 8 a.m. and the event on Saturday, June 24<sup>th</sup> from 10 a.m. to 8 p.m. Any damage to grass in the park shall be repaired/paid for by the Chamber of Commerce. **No dogs** are allowed in Village Park and this should be disseminated to and followed by event participants. Open intoxicants are allowed in Village Park.

**ALCOHOL:** Open intoxicants will be allowed (plastic cups only) on Saturday, June 24<sup>th</sup> from 11 a.m. to 11:59 p.m. inside a rectangle where the outside streets are 3<sup>rd</sup> Avenue, 2<sup>nd</sup> Street, 7<sup>th</sup> Avenue, and Railroad Street

**NOTE: Chamber must post the perimeter with open intoxicants boundary signs (No Alcohol Beyond this Point).**

**TENTS:** A 40' by 120' tent to be placed in 4<sup>th</sup> Avenue between 2<sup>nd</sup> Street and Railroad Street on Friday, June 23<sup>rd</sup> 8 a.m. to Tuesday, June 27<sup>th</sup> 4 p.m. to be secured with cement barriers and stakes. (10) 10x10's in Village Park grass and (10) 10x10's placed in 4<sup>th</sup> Avenue between 2<sup>nd</sup> Street and Railroad Street Saturday, June 24<sup>th</sup> 8 a.m. - 10 p.m. **(No in ground anchors in the street)**

**\*\*** In case of storms, tent backup plan is to have only a single 120'x60' tent in 4<sup>th</sup> Avenue between Railroad St and 2<sup>nd</sup> street. To be set up 8 a.m. Friday, June 23<sup>rd</sup> - 4 p.m. Tuesday, June 27<sup>th</sup>. Sponsor will notify Village if this change is to take place.

**DUMPSTERS:** Dumpsters will be placed at southeast corner of Village Park, in reserved parking stalls

**RESTROOMS:** Number of restrooms shall be in conformance to FEMA specifications for the number of event attendees. Indoor facilities shall be available at Chamber of Commerce, 418 Railroad Street. Outdoor facilities shall include:

- 15 regular bathrooms and 1 handicap facility, 3 sinks in parking stalls along northwest corner of Village park

**AMPLIFICATION:** Permit holder shall be permitted use of loud speakers/amplification devices to be used in Village Park for live bands on Saturday, June 24<sup>th</sup> 10 a.m. to 8 p.m. Any disassembly, taking down of equipment and clean up shall be completed without creating any noise for the neighborhood residents.

**SAFETY/SECURITY:** The permit holder shall have on file and current Emergency Action Plan for Police, Fire and EMS. This finalized updated plan shall be filed with the Village and all emergency agencies no later than fourteen (14) days prior to the event. The event anticipates attendance of 1,500 attendees.

The permit holder shall provide and pay uniformed New Glarus Police Officers as follows:

- (2) Uniformed New Glarus Police Officers working festival grounds and immediate grounds area. This shall be in effect on Saturday, June 24<sup>th</sup> one (1) Officer from 12 p.m. (noon) until 9 p.m. and a second Officer from 3 p.m. to 9 p.m.
- Estimated Cost per officer, is **\$45 per hour** per officer.

Due to the crowd size or other unforeseen matters, these hours may be extended or changed with verbal notification to the Chamber by the Chief of Police.

**SPECIAL PROVISIONS FOR TEMPORARY CLASS “B” LICENSE:**

1. Temporary Class “B” Fermented Malt Beverage issued for the serving of intoxicating beverages on June 24<sup>th</sup> between 11 a.m. to 8 p.m. located on 4<sup>th</sup> Avenue, 3<sup>rd</sup> Avenue, and Village Park (between Railroad and 2<sup>nd</sup> Street). **NOTE: The temporary alcohol license must be posted at booth.**
2. Permit holder has provided to the Village a schedule of licensed operators who will be serving alcohol at the stand. **NOTE: A licensed operator must be present at all times and all operator licenses must be posted at booth, Bekah Stauffacher and Annie O’Connor**
3. As part of the Temporary Alcohol License, a signed Release of Liability Form is on file with the Village.

**INSURANCE:** Required insurance is on file with the Village Clerk’s Office.

**MISC:** Any work performed by Village staff outside normal working hours will be billed to the permit holder.

**This event will be held only if it complies with all recommendations of the State of Wisconsin, State Health and Human Services Department, and the Green County Health department regarding large gatherings and events at the time the event is scheduled to take place. The Village reserves the right to revoke this permit if its occurrence presents a public health risk.**

PERMIT ISSUED:

\_\_\_\_\_

BY: \_\_\_\_\_  
Lauren Freeman, Administrator

**Jeff Sturdevant**  
**Chief of Police**  
sturdevant@newglaruspolice.com



Office: 608-527-2145  
Fax: 608-527-2062  
info@newglaruspolice.com

"America's Little Switzerland"

**Village of New Glarus**  
**Application for Special Event, Permit Addendum**

New Glarus Chamber "Blues Brews and Food Trucks"  
Sponsored by the New Glarus Chamber of Commerce  
Dates: June 24, 2023

**New Glarus Police Department Special Restrictions Addendum**

- A) For the New Glarus Blues, Brews and Food Truck on June 24<sup>th</sup>, the sponsor shall provide and pay for Two (2) uniformed New Glarus Police Officers\* working the festival grounds and immediate grounds area. This shall be in effect for 1 Officer from 12PM (noon) until 9 PM. Then a 2<sup>nd</sup> Officer from 3PM to 9PM.
- B) The chamber shall post their Open intoxicants boundary signs around the perimeter of the specified area.
- C) All music, equipment and other noise shall stop at 8:00 PM. Any disassembly, taking down of equipment and clean up shall be completed without creating any noise for the neighborhood residents.
- D) Shall have on file a current Emergency Action Plan for Police, Fire and EMS. This finalized updated plan shall be filed with the village and all emergency agencies, no later than 14 days prior to the events.
- E) There shall be NO PARKING of any vehicles within the permitted/designated road closed festival area once the event begins. This includes volunteers, band members, vendors, sound people, etc. Travel to and from the vendor booths and stage area is permitted for loading and unloading of equipment, supplies, etc., prior to the event starting.
- F) After initial set up, all vehicles (excluding food trucks) shall be removed from the festival area. Officers will be available to assist during band change outs accessing the backstage area. Any violators will be ticketed and may be towed. All groups/personnel requiring vehicle access to the fest area shall be advised of this by the event promoter.

Note: Due to crowd size or other unforeseen matters, these hours may be extended or changed with verbal notification to the Chamber by the Chief of Police.

\* The cost per officer, per hour at this time is not set but will increase from last year's rate of \$45.00 per hour.

# Application for Temporary Class "B" / "Class B" Retailer's License

See Additional Information on reverse side. Contact the municipal clerk if you have questions.

FEE \$ 10.00

Application Date: 03/30/2023

Town  Village  City of New Glarus

County of Green

The named organization applies for: (check appropriate box(es).)

A Temporary Class "B" license to sell fermented malt beverages at picnics or similar gatherings under s. 125.26(6), Wis. Stats.

A Temporary "Class B" license to sell wine at picnics or similar gatherings under s. 125.51(10), Wis. Stats.

at the premises described below during a special event beginning 06/24/2023 and ending 06/24/2023 and agrees to comply with all laws, resolutions, ordinances and regulations (state, federal or local) affecting the sale of fermented malt beverages and/or wine if the license is granted.

**1. Organization** (check appropriate box) →

- Bona fide Club  Church  Lodge/Society  
 Veteran's Organization  Fair Association or Agricultural Society  
 Chamber of Commerce or similar Civic or Trade Organization organized under ch. 181, Wis. Stats.

(a) Name New Glarus Chamber of Commerce

(b) Address PO Box 713, 418 Railroad Street, New Glarus WI 53574  
(Street)  Town  Village  City

(c) Date organized 08/01/1985

(d) If corporation, give date of incorporation 09/03/1985

(e) If the named organization is not required to hold a Wisconsin seller's permit pursuant to s. 77.54 (7m), Wis. Stats., check this box:

(f) Names and addresses of all officers:

President Ally Sayre, 606 Railroad Street, New Glarus WI 53574

Vice President Tory Hutchison, 600 1st Street, New Glarus WI 53574

Secretary Beth Zurbuchen, 507 Durst Road, New Glarus WI 53574

Treasurer Jon Heller, 1101 HWY 69, New Glarus WI 53574

(g) Name and address of manager or person in charge of affair: Bekah Stauffacher  
418 Railroad Street, New Glarus WI 53574

**2. Location of Premises Where Beer and/or Wine Will Be Sold, Served, Consumed, or Stored, and Areas Where Alcohol Beverage Records Will be Stored:**

(a) Street number 0 through 100 blocks of 4th Avenue, 0 through 100 blocks of 3rd Avenue, and Village Park. Beer served from 11 AM - 8 PM, 6.24.23

(b) Lot \_\_\_\_\_ Block \_\_\_\_\_

(c) Do premises occupy all or part of building? outdoor event on street and in park

(d) If part of building, describe fully all premises covered under this application, which floor or floors, or room or rooms, license is to cover: \_\_\_\_\_

**3. Name of Event**

(a) List name of the event Blues, Brews & Food Trucks

(b) Dates of event 06/24/2023

## DECLARATION

An officer of the organization, declares under penalties of law that the information provided in this application is true and correct to the best of his/her knowledge and belief. Any person who knowingly provides materially false information in an application for a license may be required to forfeit not more than \$1,000.

Officer Alexandra Jaeger 4.12.23  
(Signature / Date)

New Glarus Chamber of Commerce  
(Name of Organization)

Date Filed with Clerk 4-12-23

AWPS 5.8.23  
Date Reported to Council or Board 5.16.23

Date Granted by Council \_\_\_\_\_

License No. 23-T-4

Alcohol Servers: Bekah & Annie

# VILLAGE OF NEW GLARUS



## ADMINISTRATION DEPARTMENT

### MEMORANDUM

**To:** Village Board  
**From:** Lauren Freeman, Village Administrator & Kelsey Jenson, Village Clerk/Treasurer  
**Date:** May 16, 2023  
**Re:** 2024 Budget Timeline & Procedures

Budget season is quickly approaching. Village staff put together a preliminary timeline outlining major milestones and deadlines in the budget creation and approval process. The timeline is provided below, with Village Board actions bolded:

<b>2024 Budget Timeline:</b>	<b>Date:</b>
<b>Village Board reviews budget timeline &amp; procedures</b>	<b>May 16, 2023</b>
<b>Village Board discusses 2024 budget goals</b>	<b>June 6, 2023</b>
Clerk/Treasurer sends out historical financial information & salary and benefit figures to departments	June 15, 2023
Department 2024 Budgets, EOY Projections, and Capital Project Lists are due to Clerk/Treasurer	July 6, 2023
Administrator & Clerk/Treasurer meet with Department Heads and other Village-funded entities to review budget submissions	July 2023
Committee meetings (Public Works/Public Safety, Parks & Recreation)	August 2023
Finance/Personnel Committee reviews budget and wage recommendations for non-union employees	September 2023
<b>Village Board Budget Workshops</b>	<b>October 3 &amp; 17, 2023</b>
<b>Village Board Public Hearing &amp; Adopt FY24 Budget</b>	<b>November 7, 2023</b>

**VILLAGE OF NEW GLARUS  
ORDINANCE 23-03**

**AN ORDINANCE TO REPEAL AND RECREATE SECTION 269-2 OF THE MUNICIPAL CODE  
OF THE VILLAGE OF NEW GLARUS  
HOTEL-MOTEL ROOM TAX**

THE VILLAGE BOARD of the VILLAGE OF NEW GLARUS, GREEN COUNTY, WISCONSIN,  
does hereby ordain as follows:

**Section 1.** That Section 269-2 is hereby repealed and recreated as follows: (Additions are noted by underline, deletions are noted by ~~overstrike~~.)

**§269-2 Imposition of Tax**

- A. Scope of tax. Pursuant to § 66.0615, Wis. Stats., a tax is hereby imposed on the privilege and service of furnishing, at retail, rooms or lodging to transients by hotel keepers, motel operators and other persons furnishing accommodations that are available to the public, irrespective of whether membership is required for the use of the accommodations. Such tax shall be at a rate of 5% of the gross receipts from such retail furnishing of rooms or lodgings. Such tax shall not be subject to the selective sales tax imposed by § 77.52(2)(a)1, Wis. Stats.
- B. Use of tax proceeds.
  - (1) ~~Ninety~~ Eighty-five percent of the tax proceeds shall be used to promote tourism in the New Glarus area.
  - (2) ~~Seven~~ Twelve percent of the tax proceeds shall be returned to the Village for administration costs.
  - (3) Three percent of the tax proceeds shall be returned to the business collecting the tax.

**Section 2.** This Ordinance shall become effective upon passage and publication as provided by law.

PRESENTED: 5/16/23

ADOPTED: 5/16/23

Published:

\_\_\_\_\_  
Roger Truttman, Village President

\_\_\_\_\_  
Kelsey Jenson, Village Clerk

**Village of New Glarus  
Resolution R23-15**

**Resolution Appointing Limited Term Employee  
Public Works Laborer**

THE VILLAGE BOARD of the VILLAGE OF NEW GLARUS, GREEN COUNTY, WISCONSIN does hereby resolve to appoint James Nelson to a limited term public works laborer position. Said term will begin May 30, 2023. Hours for this position will be in line with the current budget and in no case more than 330 hours per year. Compensation for said position shall be \$15.30 per hour.

DATE: 5/16/2023

ADOPTED: 5/16/2023

---

Roger Truttman, President

---

Kelsey Jenson, Clerk

**Village of New Glarus  
Resolution R23-16**

**Resolution Appointing Limited Term Employee  
Parks and Recreation Laborer**

THE VILLAGE BOARD of the VILLAGE OF NEW GLARUS, GREEN COUNTY, WISCONSIN does hereby resolve to appoint Owen Palmer to a limited term parks and recreation laborer position. Said term will begin May 30, 2023. Hours for this position will be in line with the current budget and in no case more than 400 hours per year. Compensation for said position shall be \$15.00 per hour.

DATE: 5/16/2023

ADOPTED: 5/16/2023

\_\_\_\_\_  
Roger Truttmann, President

\_\_\_\_\_  
Kelsey Jenson, Clerk



**Village of New Glarus  
Resolution R23-17**

**To Appoint Lifeguards, Water Safety Instructors, and Field Supervisor- 2023 Season**

THE VILLAGE BOARD of the VILLAGE OF NEW GLARUS, GREEN COUNTY, WISCONSIN does hereby resolve to appoint the following individuals to limited term positions during the 2023 summer recreation season:

<u>NAME</u>	<u>POSITION</u>	<u>HOURLY RATE</u>
Megan Buol	Aquatics Director-Full time	\$18.65
Chris Rear	Parks/Recreation Director	\$17.49
Kayla Zimmerman	Aquatics Consultant-Part time	\$17.49
Stephanie Zweifel	Guard/WSI-Part time	\$15.43
Kari Morrison	Guard I and Swim Coach	\$11.25
Eli Zimmerman	Guard I and Swim Coach	\$11.25
Mason Thompson	Part Time WSI Guard I	\$11.25
Karley Michels	Part Time Guard I	\$11.25
Emery Johnson	Part Time Guard I	\$9.00*
Riley O'Flanagan	Full Time Guard I	\$11.25
Sydney O'Flanagan	Full Time Guard I	\$11.25
Breckyn Thompson	Full Time Guard I	\$9.00*
Nathan Heil	Part Time Guard I	\$9.00*
Camryn Arnett	Part Time Guard I	\$9.00*
Delaney Lynch	Part Time Guard I	\$9.00*
Ellie Eichelkraut	Part Time Guard I	\$11.25
Simon Zimmerman	Part Time Guard I	\$9.00*
Clem Meter Brooks	Part Time Guard I	\$9.00*
Delaney Hoeper	Part Time Guard I	\$9.00*
Carter Nemergut	Part Time Guard I	\$9.00*
Dunnell Kendrick	Part Time Lessons Instructor	\$12.00

Any employee hired as a Guard I who receives WSI certification shall be re-classed to Guard II or Guard III (depending on full or part time status) and receive the Guard II/Guard III wages based on their years of experience with the Village.

\* - Lifeguards that plan on becoming WSI certified during the 2023 season (pay increase to \$11/hour will occur at that time).

The Village's policy for uniform (swimsuit) reimbursement is as follows:

Full-time employees [Guard III] shall be eligible for one-hundred (100) percent reimbursement up to \$70.00

Part-time employees [Guard I and II and subs] shall be eligible for fifty (50) percent reimbursement up to \$35.00

Substitute Employees:

Emily Streiff	Substitute WSI Guard III	\$ 11.00
Keatan Zimmerman	Substitute WSI Guard III	\$ 11.00
Lindsey Schadewalt	Substitute Guard I	\$ 9.00

The employees shall be paid in accordance with R22-04.

THE VILLAGE BOARD of the VILLAGE OF NEW GLARUS, GREEN COUNTY, WISCONSIN does hereby further resolve to contract with Jacob Rice for Certified Pool Operator services for the Village of New Glarus for the 2023 season. The Certified Pool Operator shall be responsible for the operation of the pool, including the mechanical systems operations under the direction of the Aquatics director, as required by State Code.

DATE: 5/16/23  
ADOPTED: 5/16/23

---

Roger Truttman, President

---

Kelsey A Jensen, Clerk

# VILLAGE OF NEW GLARUS



---

## MEMORANDUM

---

**To:** Parks & Recreation Committee  
**From:** Amy Trumble, Library Director  
**Date:** May 10, 2023  
**Re:** Charging Station at Village Park

---

I know a while back Erica had come to a Parks meeting to get approval for the charging pole to be placed in Village Park. We now have the charging pole and it is ready to install. Since the time of the approval, we have been approached with the offer of a Polywood bench (from the Lion's plastic bag collections) that could be situated adjacent to the charging station. I believe we would have to get a new approval in order to modify the plan (first from Parks and then from the Village Board).

The changes to the original plan that we would be looking at are:

- Instead of a 16" x 16" square of concrete we would be looking at a 12' x 8' pouring for the bench and charging pole (The Friends of the Library agreed to fund this if approved. The estimate from Bobby Pernot is attached).
- Originally, it was to be placed somewhere near the shelter. After talking with Joe, the thought was to put it between the shelter and 2<sup>nd</sup> Street. Situating it away from the play area. (See attached pdf map of proposed new location. The map is not to scale.).

I have also attached pictures of the bench and a similar set up with a bench and charging pole that I received from the Sun Charge Systems company representative (The picture shows two benches and two charging poles, we would have one of each).

With all of the activity that takes place downtown and in Village Park during the year, visitors might benefit from a spot to sit and recharge their phones while taking in all that New Glarus has to offer. Having it situated away from the play area a bit may help ensure that it is used for its intended purpose and kids at the park don't think it is another thing for them to be playing with. Joe and I also considered set up and take down of park events and it should not interfere with those activities, nor should it interfere with snow removal on the sidewalks during the winter months. If you have any other questions or concerns that I may have forgotten to address, please let me know.

Bench Picture:



Bench Dimensions:

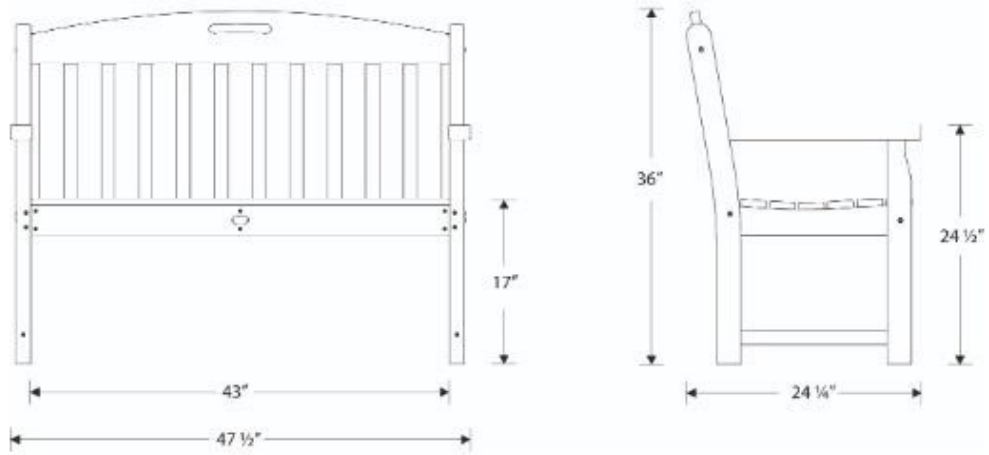

Charging Poles:



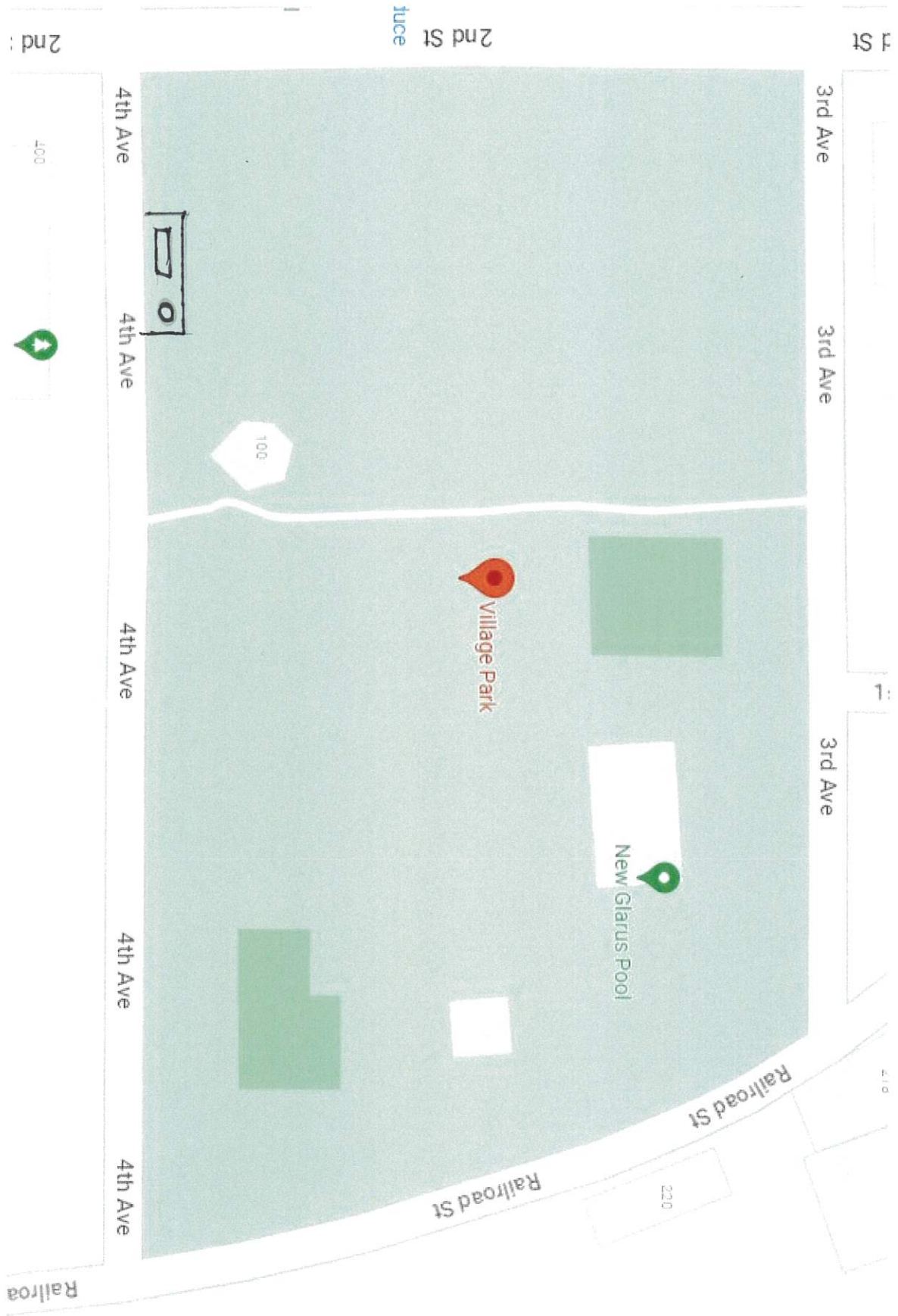

**VILLAGE OF NEW GLARUS  
ORDINANCE 23-04**

**AN ORDINANCE TO STRIKE SECTION 288-21 (H) OF THE MUNICIPAL CODE OF THE  
VILLAGE OF NEW GLARUS  
PARKING REGULATIONS**

THE VILLAGE BOARD of the VILLAGE OF NEW GLARUS, GREEN COUNTY, WISCONSIN,  
does hereby ordain as follows:

**Section 1.** That Section 288-21 (H) is repealed as follows: (Deletions are noted by ~~overstrike~~.)

**§288-21 Parking prohibited zones.**

~~(H) The north side of Fourth Avenue from the west edge of the driveway at Fourth Street to a  
point 165 feet east.~~

**Section 2.** This Ordinance shall become effective upon passage and publication as provided by  
law.

PRESENTED: 5/16/23

ADOPTED: 5/16/23

Published:

---

Roger Truttmann, Village President

---

Kelsey Jenson, Village Clerk

REPORT ON PROPOSED SPECIAL ASSESSMENTS FOR PUBLIC IMPROVEMENTS  
AGAINST PROPERTIES LOCATED IN NEW GLARUS, WISCONSIN

VILLAGE OF NEW GLARUS, WISCONSIN

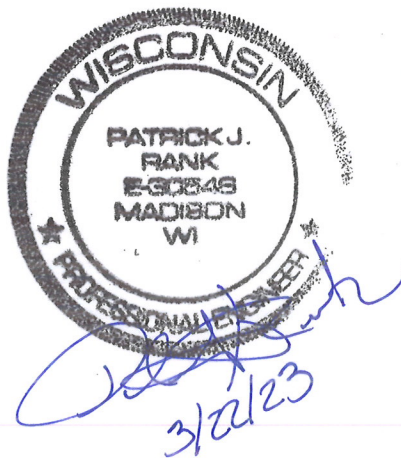

Strand Associates, Inc.®  
Excellence in Engineering Since 1946  
910 West Wingra Drive  
Madison, WI 53715

March 22, 2023



This report is submitted in accordance with the requirements of s.66.0703, Stats., and the preliminary resolution of the municipal governing body of New Glarus, Wisconsin, dated March 21, 2023, determining to levy special assessments on benefited properties for public improvements described in Schedule B of this report to be made in the assessment district as described in Schedule C included in this report.

This report consists of the following schedules attached hereto:

- Schedule A—Final drawings and specifications.
- Schedule B—Estimate of entire cost of proposed improvements.
- Schedule C—Schedule of proposed assessments against each benefited parcel.

## SCHEDULE B

### ESTIMATE OF ENTIRE COST OF PROPOSED IMPROVEMENTS

The estimated total cost of improving the following named streets and portions thereof in accordance with the drawings and specifications in Schedule A is \$1,417,280. This cost is determined as follows:

For Street and Utility Construction:

Street Construction	\$ 585,010
Sanitary Sewer	\$ 132,890
Storm Sewer	\$ 314,355
Water Main	\$ 142,525
Engineering, Legal, and Administrative	<u>\$ 242,500</u>
<b>Total estimated cost</b>	<b>\$ 1,417,280</b>

#### Location of Improvements

- Third Avenue between Third Street and Eighth Street

#### **30-IN Curb and Gutter (per Front Foot)**

Construction Cost	\$19.00
Engineering, Legal, and Administrative	<u>\$ 3.25</u>
<b>Cost per Front Foot</b>	<b>\$22.25</b>

**Curb and Gutter Removal (per Front Foot)**

Construction Cost	\$3.00
Engineering, Legal, and Administrative	<u>\$0.51</u>
Cost per Front Foot	<b>\$3.51</b>

**Concrete Sidewalk (per Square Foot)**

Construction Cost	\$6.10
Engineering, Legal, and Administrative	<u>\$1.04</u>
Cost per Square Foot	<b>\$7.14</b>

**Concrete Sidewalk Removal (per Square Foot)**

Construction Cost	\$5.00
Engineering, Legal, and Administrative	<u>\$0.86</u>
Cost per Square Foot	<b>\$5.86</b>

**SCHEDULE C**

PROPOSED ASSESSMENTS - VILLAGE OF NEW GLARUS - THIRD AVENUE – PHASE 2

The following properties to which the proposed assessments are to be made are benefited.

Police Power Assessments

PARCEL #	NAME	Property Address	Mailing Address	City_St_ZIP	Total Front Footage 30 - Inch Curb and Gutter (LF)	Total Front Footage Curb and Gutter Removal (LF)	Total Square Feet (sq. ft) Sidewalk	Total Square Feet (sq. ft) Sidewalk Removal	Estimated Total \$
23161 0247.0000	New Glarus Bible Church	207 6th Street	207 6th Street	New Glarus, WI 53574	0.00	0.00	0.00	0.00	\$ -
23161 0247.0000	New Glarus Bible Church	619 3rd Avenue	207 6th Street	New Glarus, WI 53574	0.00	0.00	0.00	0.00	\$ -
23161 0243.1000	New Glarus Bible Church	OL 24A	207 6th Street	New Glarus, WI 53574	33.00	33.00	0.00	0.00	\$ 850.08
23161 0248.1400	Timothy & Mary Usher	701 3rd Avenue	701 3rd Avenue	New Glarus, WI 53574	108.86	108.86	0.00	0.00	\$ 2,804.23
23161 0248.1300	Rosalie Huntington	707 3rd Avenue	PO Box 631	New Glarus, WI 53574	88.00	88.00	0.00	0.00	\$ 2,266.88
23161 0248.1200	Shane & Danielle Tonn	300 8th Street	300 8th Street	New Glarus, WI 53574	180.00	180.00	0.00	0.00	\$ 4,636.80
23161 0220.1000	New Glarus Home Inc	701 Haslen Dr	600 2nd Avenue	New Glarus, WI 53574	6.00	6.00	0.00	0.00	\$ 154.56
23161 0779.0000	Linda K Hiland	801 3rd Avenue	801 3rd Avenue	New Glarus, WI 53574	50.00	50.00	0.00	0.00	\$ 1,288.00
23161 0292.0000	New Glarus Volunteer Fire Department Inc	219 3rd Avenue	PO Box 306	New Glarus, WI 53574	0.00	0.00	0.00	0.00	\$ -
23161 0291.0100	New Glarus Fire District	218 4th Avenue	212 4th Avenue	New Glarus, WI 53574	0.00	0.00	0.00	0.00	\$ -
23161 0290.0200	Village of New Glarus	312 4th Avenue	PO Box 399	New Glarus, WI 53574	0.00	0.00	0.00	0.00	\$ -
23161 0282.0000	Delayne & Merton Retrum	401 3rd Avenue	401 3rd Avenue	New Glarus, WI 53574	0.00	0.00	0.00	0.00	\$ -
23161 0261.1000	New Glarus/Dodgeville LIHTC LLC	301 5th Street	4801 Tradewinds Parkway	Madison, WI 53718	0.00	0.00	0.00	0.00	\$ -
23161 0261.2000	Brian & Sally Jeglum	519 3rd Avenue	W5911 Durst Road	New Glarus, WI 53574	0.00	0.00	0.00	0.00	\$ -
23161 0261.0000	Carolyn & Jeffrey Babler	506 3rd Avenue	PO Box 646	New Glarus, WI 53574	0.00	0.00	0.00	0.00	\$ -
23161 0267.2000	Brenkman Living Trust	518 3rd Avenue	518 3rd Avenue	New Glarus, WI 53574	0.00	0.00	0.00	0.00	\$ -
23161 0262.0000	Julie & Paul Jennrich	201 5th Street	201 5th Street	New Glarus, WI 53574	0.00	0.00	0.00	0.00	\$ -
<b>TOTAL</b>					<b>465.86</b>	<b>465.86</b>	<b>0.00</b>	<b>0.00</b>	<b>\$ 12,000.55</b>



## Statement of Qualifications 2024 Reservoir Construction



Creative Solutions for Your Community Since 1981

6264 Nesbitt Road  
Madison, WI 53719  
(608) 273-3350

10505 Corporate Drive  
Suite 105A  
Pleasant Prairie, WI 53158  
(262) 925-3210

150 S. Anderson Street  
Suite 3  
Rhineland, WI 54501  
(715) 420-0579

## Company Profile

---

Town & Country Engineering was founded in 1981 to fill a gap left by larger consulting engineering firms by providing personalized service to municipalities, at a minimal cost, that meet or exceed the designs and analyses provided by larger, more expensive engineering firms.

Our company, with offices located in Madison, Rhinelander and Kenosha, is a multifaceted Municipal engineering firm that provides a wide range of services including general municipal engineering, wastewater and water supply design and GIS mapping. We are dedicated to providing quality service at the lowest possible overhead cost and have been proudly working with Wisconsin communities for over 40 years.

We focus our work on governmental bodies. **To avoid even the appearance of a conflict of interest, we do not work for developers or DOT.** Our work for most of our clients includes functioning as the municipal engineer for all street and utility infrastructure needs, review of plats, certified surveys and developments, and assistance in ordinance development.

We provide planning, design, and construction services for water supply, wastewater treatment, stormwater management, GIS, and municipal engineering projects. We are involved in SCADA design, facility operations, and biological evaluation for both water and wastewater systems.

A primary client contact is assigned to each community, with a designated principal responsible for oversight and overall client satisfaction. The work of the professional engineering staff, engineering technicians, and office administrative staff are supervised by the primary client contact. Town & Country Engineering has a staff that includes Wisconsin licensed professional engineers, staff engineers, engineering technicians, administrative staff, and part-time staff spread throughout our 3 offices in Madison, Rhinelander, and Kenosha.

## Our Approach to Consulting Services

---

Town & Country Engineering, Inc. was formed with a unique philosophy of service. **We strive to become a part of the community by periodic meeting attendance and making ourselves readily available for questions and consultation.** We encourage our clients' officials and staff to reach out to us whenever questions arise. We feel that a relatively minor commitment of our time, at no charge, can often save much of our clients' time and expense.

We recognize that we are professional advisors only, and the ultimate decisions regarding projects belong with the staff and elected officials of our clients.

For services on projects which cannot be easily defined in advance, we suggest that hourly rates for our personnel be established for each project or for each calendar year, and that we charge the client for our services based upon the hours actually used. **We do not charge for preparing cost estimates for public works construction projects or assisting in the development of capital improvement plans.**

For specific projects we are agreeable to any of several forms of contracts, including hourly, hourly not-to-exceed, lump sum, and cost-plus fixed fee. Whatever the type of contract, we believe the client should know in advance what range of costs to expect. Therefore, on all projects, we provide an estimate of the cost of our services before we begin. Should additional engineering expenditures become necessary, we notify the client in advance to obtain the client's concurrence before proceeding with the extra work.



# Project Team and Qualifications

---

## Current and Projected Workload

Because our business is based on providing engineering services to municipalities, we do not experience the workload demand cycles that other firms may. This allows us to adequately match available staff with potential workload. We also work with our clients to prepare and update their capital improvement plans which allows us to have a fairly accurate idea of future workload. Providing a high level of service to our client communities is always a priority, and we are selective about potential new clients to ensure consistent quality. We have never missed a critical deadline for any of our projects. Our project team and our firm has the resources to complete this project within the Village's schedule.



### **MR. BRIAN BERQUIST, P.E. - PRESIDENT**

Mr. Berquist is the President of Town & Country Engineering and will provide project engineering and QA/QC review. He works primarily with Municipal Engineering, Surveying, and GIS. Brian has over 20 years of experience working in a variety of stormwater and roadway design projects, as well as working as Village Engineer with multiple communities to secure grants, review developers plans and agreements, and providing general support to planning, building, and administrative departments. He works with a client from project inception through the completion of a project, to ensure continuity throughout. Brian recognizes that his role is to assist the community in making sound decisions for both the interim and future alike.



### **MR. NICK BUBOLZ, P.E. - PROJECT ENGINEER**

Mr. Bubolz is a Project Engineer with Town & Country Engineering and will provide project engineering and drafting. He works primarily with Municipal Engineering projects. Nick has over 10 years experience working with communities on roadway design projects and utility reconstruction. He also works as Village Engineer with multiple communities reviewing developer plans, providing general support to staff, and providing project management on municipal projects.



### **MS. AMY BARES, P.E. - DRINKING WATER AND FUNDING LEAD**

Ms. Bares is a Senior Project Engineer and partner at Town & Country Engineering and will provide project engineering and funding coordination. She works with both water/wastewater and municipal engineering projects with over 20 years of experience in the field. Amy serves as our technical lead for both drinking water and funding, supporting our engineers and client communities in these fields. Amy has experience in water system capacity evaluation and modeling, master planning, regulatory compliance assistance, and permitting and design for water system improvements, including siting and design for municipal wells and water storage. Amy has extensive experience in obtaining funding for infrastructure improvements, including low-interest loans and principal forgiveness from the DNR's Safe Drinking Water and Clean Water Fund programs and loans and grants from USDA Rural Development program.

## Related Project Experience and References

### Village of Deerfield - 650,000 Gallon Water Storage Reservoir and Connecting Water Main

The Village of Deerfield worked with Town & Country Engineering to construct a new 650,000 gallon water storage reservoir to replace an existing reservoir. The location and height of the tank was selected to increase static pressures throughout the Village and eliminate an existing booster station, with the tank sizing to provide adequate storage for fire protection and future growth.

Town & Country Engineering was responsible for design and construction oversight on the reservoir, water main connection, and access road, as well as permitting and coordination with DNR and PSC. Several types of ground reservoirs were evaluated based on life cycle costs, including capital cost, maintenance/painting requirements, and resistance to corrosion. Two reservoir types were included in the bid documents, glass-lined bolted steel and bolted stainless steel, and the Village selected a glass-lined bolted steel tank with aluminum dome cover for construction. The tank was designed with an integral valve vault, reinforced concrete slab floor, recirculation pump and piping, and standard appurtenances for venting and access.

**Contact: Nate Paoli, Director of Public Works, (608) 764-5497**



## Related Project Experience and References

### Village of Tennyson - 150,000 Gallon Water Tower and Connecting Water Main

The Village of Tennyson worked with Town & Country Engineering to replace their existing stand pipe with a new 150,000 gallon elevated spheroid tank to address long-standing problems with static pressures in high elevation areas and fire flow deficiencies.

Town & Country Engineering was responsible for the design of the water tower, including water main connections to the existing distribution system and integration into the Village's SCADA system. We facilitated the Village's selection and purchase of the new tower site based on elevations, available land locations, and geotechnical investigations. Appurtenances for the tower included a water recirculation system, pipe insulation, access ladders, hatchways, lights, railings, intermediate platforms, and conduit and wiring provisions for future cellular/communications equipment. A small interior building was constructed around the inlet pipe, recirculation pump and pressure panel to reduce the footprint of heated space in the tower base.

Town and Country oversaw the construction, from site grading and excavation for the foundation to construction of the tower, with painting inspection provided by a third party. We also coordinated funding for the project through USDA Rural Development and approval from DNR and PSC for construction.

**Contacts: Ben Reynolds, Director of Public Works, (414) 510-5412 / Keith Jantzen, Village President, (608) 763-2912**







Creative Solutions for Your Community Since 1981

6264 Nesbitt Road  
Madison, WI 53719  
(608) 273-3350

10505 Corporate Drive • Suite 105A  
Pleasant Prairie, WI 53158  
(262) 925-3210

150 S. Anderson Street • Suite 3  
Rhineland, WI 54501  
(715) 420-0579

[www.tcengineers.net](http://www.tcengineers.net)

## MEMORANDUM

---

Date: May 2, 2023

To: Ms. Lauren Freeman, Administrator  
Village of New Glarus  
319 2nd Street, P.O. Box 399  
New Glarus WI 53574

From: Brian Berquist, P.E.

Subject: Water Reservoir Construction Type Discussion

---

The intent of this memorandum is to review recent meetings, discussions and decisions related to the construction style of a proposed second reservoir for the Village's drinking water system.

The attached worksheet outlines three of the most commonly utilized methods for constructing a tank of this size in southern Wisconsin (welded steel, bolted steel and pre-stressed concrete). After initial discussions with contractors and suppliers, preliminary cost estimates were created, as shown in the attachment. It was observed that all of the construction types result in very similar estimated construction costs of roughly \$2.3 million. Follow-up discussions with Village staff confirmed no particular preference for the operational features of each, which left long-term maintenance as the most significant difference between the tanks.

Bolted steel was attractive because there is no need to regularly paint the outside. Discussions with other communities with this type of tank revealed some concern that future repairs might prove difficult given the potential of a large number of bolts involved.

Welded steel (the type in place at Reservoir No. 1 in the Village) has provided good service for many years. However, painting on both the inside and outside to protect the steel for longer life is required approximately every 20 to 30 years.

Pre-stressed concrete has become more popular as construction technology evolves, because it does not require any paint. Architectural features such as faux columns and painted designs can be incorporated on the outside of the tank as the Village desires.

The proposed location of Reservoir No. 2, on the eastern ridge of the valley, may require some excavation to keep the tank at the proper elevation. This would prove difficult for either bolted steel or welded steel, as those materials perform poorly underground. Pre-stressed concrete has the ability to be constructed and partially buried underground if necessary to achieve the desired elevations.

For these reasons, staff has selected pre-stressed concrete as the preferred tank type. We will pursue this option when composing the design documents to be used for permitting and bidding the project over the next six to nine months.

Please let us know if you would like us to present this material at an upcoming committee or board meeting.

cc: Mr. Joe Cockroft, Public Works Director, Village of New Glarus (319 2nd Street, P.O. Box 399, New Glarus WI 53574)

BRB:sai

J:\JOB#S\New Glarus\NG-51-M9 Reservoir Preliminary Engineering\Admin\Water Reservoir Construction Type Discussion Memo.docx

**VILLAGE OF NEW GLARUS - WATER STORAGE TANK ALTERNATIVES**

TANK CAPACITY: 300,000 GALLONS

March 2023

		Glass-Coated, Bolted Steel Tank, Aluminum Cover	Welded Steel, Epoxy Coated, Steel Roof	Prestressed Concrete, Flat or Dome Conc Roof
<i>Manufacturer</i>		CST Aquastore	CB&I/McDermott	DN Tanks
<i>Dimensions &amp; Capacity</i>		44.76' diameter x 28.43' high	41' diameter x 32' high	41.33' x 30' SWD
General Site Work		\$64,500	\$64,500	\$64,500
Excavation		\$46,700	\$46,700	\$46,700
Structural Fill		\$46,700	\$46,700	\$46,700
Foundation and Floor Slab		\$77,900	Included in Tank Price - standard shallow foundation	Included in Tank Price - standard shallow foundation
Tank		\$553,000	\$765,000	\$725,000
Tank Cover		Included in Tank Price - Geodesic Dome	Included in Tank Price - Steel Cone	Included in Tank Price - Concrete Dome
Ladders, Manways & Hatches		Included in Tank Price	Included in Tank Price	Included in Tank Price
Valve Manhole, Piping & Valves		\$67,000	\$67,000	\$67,000
Access Roadway		\$22,400	\$22,400	\$22,400
Mixing System		\$40,000	\$40,000	\$40,000
Cathodic Protection		\$20,000	\$20,000	Not Needed
Electrical and Controls		\$137,600	\$137,600	\$137,600
Electrical Service		\$25,000	\$25,000	\$25,000
Additional Contractor Costs	15%	\$165,100	\$185,200.00	\$176,200
Connecting Main		\$373,000	\$373,000.00	\$373,000
<b>CONSTRUCTION SUBTOTAL</b>		<b>\$1,638,900</b>	<b>\$1,793,100</b>	<b>\$1,724,100</b>
Contingency	15%	\$245,800	\$269,000	\$258,600
Engineering, Admin, Legal	13%	\$213,100	\$233,100	\$224,100
Construction Observation	4%	\$65,600	\$71,700	\$69,000
<b>TOTAL</b>		<b>\$2,163,400</b>	<b>\$2,366,900</b>	<b>\$2,275,800</b>
<b>ADVANTAGES:</b>		- Lower maintenance requirements (no painting)  - Glass coating fused to steel resists corrosion, with cathodic protection - Faster/modular construction	- Variety of color choices, can include lettering, logos, graphics (cost does not include lettering/logos)	- Lower maintenance requirements (no interior painting, exterior is painted concrete) - Designed for ice formation (may not need mixing) - Cathodic protection not needed
<b>DISADVANTAGES:</b>		- Possible corrosion problems if glass coating is chipped, cracked, or damaged - Cannot repair coating without consulting manufacturer - Only 5 standard color choices - panels are epoxy coated in factory	- Requires routine maintenance, recoating of interior and exterior every 15-20 years	- Exterior will require routine cleaning and possible repainting

FRIENDS OF THE CHALET OF THE GOLDEN FLEECE 10<sup>th</sup> ANNIVERSARY  
PROCLAMATION

WHEREAS, the Friends of the Chalet of the Golden Fleece are celebrating their 10<sup>th</sup> anniversary this year; and

WHEREAS, over the past decade, the Friends have been operating the Chalet of the Golden Fleece house museum on behalf of the Village; and

WHEREAS, the Friends have provided guided tours, written grants, taken care of the museum collection, and performed renovations at the Chalet since 2013; and

WHEREAS, it is the desire of the New Glarus Board of Trustees to recognize the commitment of the Friends of the Chalet of the Golden Fleece who have helped maintain the Chalet as a destination for Village residents and tourists alike.

NOW THEREFORE, on behalf of the New Glarus Board of Trustees, I hereby recognize and thank the Friends of the Chalet of the Golden Fleece for their ten years of service operating this gift from, and residence of, Edwin Barlow Mathers.

Dated this 16th day of May, 2023.

Larry Stuessy, Trustee  
Village of New Glarus

**VILLAGE OF NEW GLARUS  
2023 COMMITTEE APPOINTMENTS**

Approved by Village Board

5/16/2023

**FINANCE/PERSONNEL**

**ADDRESS**

**PRIMARY #**

**SECONDARY #**

**EMAIL**

Roger Truttmann, Chair	PO Box 213	New Glarus	WI	53574	212-6785	212-6785	rtruttmann@newglarusvillage.com
Peggy Kruse	219 Durst Rd	New Glarus	WI	53574	527-2769	444-9346	pkruise@newglarusvillage.com
Michael Bell	1018 Tower Circle	New Glarus	WI	53574	214-4224	N/A	mbell@newglarusvillage.com

**PUBLIC WORKS/SAFETY**

Peggy Kruse, Chair	219 Durst Rd	New Glarus	WI	53574	527-2769	444-9346	pkruise@newglarusvillage.com
Gof Thomson	1100 2nd St	New Glarus	WI	53574	214-5642	N/A	thomson@newglarusvillage.com
Michael Bell	1018 Tower Circle	New Glarus	WI	53574	214-4224	N/A	mbell@newglarusvillage.com

**PARKS & RECREATION**

Chuck Phillipson, Chair	PO Box 82	New Glarus	WI	53574	558-4610	N/A	cphillipson@newglarusvillage.com
Mike Marty	618 14th Ave	New Glarus	WI	53574	209-5284	N/A	mmarty@newglarusvillage.com
Larry Stuessy	318 2nd Ave	New Glarus	WI	53574	527-4155	N/A	lstuessy@newglarusvillage.com

**ADA COMPLIANCE**

**PRIMARY #**

**TERM**

**EMAIL**

Roger Truttmann (Chair)	PO Box 213	New Glarus	WI	53574	212-6785	indef.	rtruttmann@newglarusvillage.com
Laura Eicher, New Glarus School	PO Box 37	New Glarus	WI	53574	527-2810	apt. 5/11	laura.eicher@ngsd.k12.wi.us
Matt Streiff, NG Home Adm.	600 2nd Avenue	New Glarus	WI	53574	626-2421	apt. 5/23	mattstreiff@nghome.org
Larry Hendrickson, Citizen	PO Box 395	New Glarus	WI	53574	527-5319	apt. 8/92	N/A
SSM Health Designee	1800 2nd St	New Glarus	WI	53574	527-5296	N/A	N/A

**LOSS CONTROL/SAFETY**

Jeff Sturdevant	313 2nd Street	New Glarus	WI	53574	indef.	indef.	527-3680	558-5770	sturdevant@newglaruspolice.com
Kelsey Jenson	319 2nd Street	New Glarus	WI	53574	indef.	indef.	527-5973	N/A	ngclerk@newglarusvillage.com
Joe Cockroft	319 2nd Street	New Glarus	WI	53574	indef.	indef.	527-2097	558-5771	pwdirector@newglarusvillage.com
Lauren Freeman, Chair	319 2nd Street	New Glarus	WI	53574	indef.	indef.	527-5971	N/A	administrator@newglarusvillage.com
Roger Truttmann, President	PO Box 213	New Glarus	WI	53574	indef.	indef.	212-6785	212-6785	rtruttmann@newglarusvillage.com

**DESIGN REVIEW COMMITTEE**

Kaye Gmur, Chair	PO Box 191	New Glarus	WI	53574	3 years	4/30/2026	527-2533	287-4700	klgmur@gmail.com
Jacqueline Judd	500 4th Avenue	New Glarus	WI	53574	3 years	4/30/2026	636-3241	N/A	jackie.judd.scheurer@gmail.com
Pat Thorson	713 1st Street	New Glarus	WI	53574	3 years	4/30/2026	527-6024	N/A	wxframe@tds.net
Laci Bainbridge	307 Heidi Court	New Glarus	WI	53574	3 years	4/30/2026	417-331-3272	N/A	larissabainbridge@gmail.com
Larry Stuessy	318 2nd Ave	New Glarus	WI	53574	2 years	4/30/2025	527-4155	N/A	lstuessy@newglarusvillage.com

\*contacted, no response

**VILLAGE OF NEW GLARUS  
2023 COMMITTEE APPOINTMENTS**

**PLAN COMMISSION**

				<b>TERM</b>	<b>EXPIRES</b>	<b>PRIMARY #</b>	<b>SECONDARY #</b>	<b>EMAIL</b>		
Roger Truttmann, Chair	PO Box 213	New Glarus	WI	53574	2 years	4/30/2025	212-6785	212-6785	rtruttmann@newglarusvillage.com	Must be Village President
Chuck Phillipson	PO Box 82	New Glarus	WI	53574	2 years	4/30/2024	558-4610	N/A	cphillipson@newglarusvillage.com	Trustee - Appointed by 2/3 vote of Village Bd
Beth Alderman	612 4th Ave	New Glarus	WI	53574	3 years	4/30/2024	527-4835	N/A	bethalderman62@yahoo.com	
Bekah Stauffacher	719 5th Street	New Glarus	WI	53574	3 years	4/30/2026	527-2095	N/A	bekah@swisstown.com	
Tara Wilde	182 Valle Tell Dr.	New Glarus	WI	53574	3 years	4/30/2026	558-4940	527-4005	WildeT@FirstWeber.com	5 Citizen members
Mike Marty	618 14th Ave	New Glarus	WI	53574	3 years	4/30/2024	209-5284	N/A	mmarty@newglarusvillage.com	appt'd by President
Suzi Janowiak	PO Box 142	New Glarus	WI	53574	3 years	4/30/2024	558-4558	N/A	suzij2001@yahoo.com	confirmed by Board

**JOINT ETZ COMMISSION**

Roger Truttmann, Chair	PO Box 213	New Glarus	WI	53574	N/A	N/A	212-6785	212-6785	rtruttmann@newglarusvillage.com	
Bekah Stauffacher	719 5th Street	New Glarus	WI	53574	N/A	N/A	527-2095	N/A	bekah@swisstown.com	
Suzi Janowiak	207 2nd Street	New Glarus	WI	53574	N/A	N/A	527-4220	N/A	suzij2001@yahoo.com	
Robert Elkins (T-NG)	PO Box 448	New Glarus	WI	53574	N/A	N/A	527-2390	219-0857	elkinds.robert.w@gmail.com	
Jim Hoesly (T-NG)	PO Box 448	New Glarus	WI	53574	N/A	N/A	527-2390	636-0073	jhoesly@townofnewglarus.com	
Chris Narveson (T-NG)	PO Box 448	New Glarus	WI	53574	N/A	N/A	527-2390	636-3495	cnarveson@townofnewglarus.com	
<b>VACANT (T-Exeter)</b>		<b>Belleville</b>	<b>WI</b>	<b>53508</b>	<b>N/A</b>	<b>N/A</b>				
Paul O'Connor (T-Exeter)	N8114 Buol Rd	Belleville	WI	53508	N/A	N/A	354-4605	N/A		
Ted Fahey (T-Exeter)	W3858 Fahey Rd	Belleville	WI	53508	N/A	N/A	424-6331	N/A		

**HISTORICAL PRESERVATION**

Larry Stuessy	318 2nd Ave	New Glarus	WI	53574	2 years	4/1/2025	527-4155	N/A	lstuessy@newglarusvillage.com	All 7 members appointed by President, confirmed by Bd.
Victoria Fuller	707 1st Street	New Glarus	WI	53574	3 years	4/30/2024	520-2303	N/A	hellomusic42@gmail.com	
Tim Usher	701 3rd Avenue	New Glarus	WI	53574	3 years	4/30/2025	527-2469	N/A	tmush53@gmail.com	If available should consist of
Barbara Anderson	PO Box 1	New Glarus	WI	53574	3 years	4/30/2026	527-5146	558-8767	grammybarb@tds.net	Trustee, an architect,
Bekah Stauffacher	719 5th Street	New Glarus	WI	53574	3 years	4/30/2026	527-2095	N/A	bekah@swisstown.com	historian, a real estate
Kim Tschudy	PO Box 416	New Glarus	WI	53574	3 years	4/30/2025	527-5637	N/A	milroad@yahoo.com	broker & 3 citizen members
<b>VACANT</b>		<b>New Glarus</b>	<b>WI</b>	<b>53574</b>	<b>3 years</b>	<b>4/30/2026</b>				
Robert Elkins (Ex-Officio)	PO Box 247	New Glarus	WI	53574	4 years	4/30/2026	527-2803	N/A	elkins.robert.w@gmail.com	*contacted no response

**TOURISM COMMISSION**

						<b>State Stat.</b>				
Tori Hutchinson	600 1st St	New Glarus	WI	53574	2 year	4/30/2025	626-2300	N/A	seek@hutchandhide.com	
Brianna Lenzlinger (Chalet Landhaus)	PO Box 878	New Glarus	WI	53574	2 year	4/30/2025	527-5234	N/A	briana@chaletlandhaus.com	Include 1 hotel/motel rep and 4 citizens
Beth Luchsinger	318 9th Avenue	New Glarus	WI	53574	2 year	4/30/2025	206-7412	N/A	beth.luchsinger@yahoo.com	
Roger Truttmann	518 4th Avenue	New Glarus	WI	53574	2 year	4/30/2025	212-6785	N/A	rtruttmann@newglarusvillage.com	Shall meet by 5/1 to elect Chair & Officers
Brad Beal	PO Box 266	New Glarus	WI	53574	2 year	4/30/2025	527-2324	N/A	blbeal@tds.net	

**LIBRARY BOARD**

Linda Hiland [Pres]	N/A	N/A	N/A	N/A	3 years	4/30/2024	N/A	N/A	libraryboard@ngpl.org	1 Trustee and 6 Citizens,
Beth Blahut	N/A	N/A	N/A	N/A	3 years	4/30/2025	N/A	N/A	libraryboard@ngpl.org	2 members can be from adjacent Towns Citizen
Tiffany Kuenzi	N/A	N/A	N/A	N/A	3 years	4/30/2025	N/A	N/A	libraryboard@ngpl.org	Citizens appt'd by Pres. & confirmed by Bd.
Suzi Janowiak	N/A	N/A	N/A	N/A	3 years	4/30/2024	N/A	N/A	libraryboard@ngpl.org	members elect officers
Shelly Truttmann	N/A	N/A	N/A	N/A	3 years	4/30/2026	N/A	N/A	libraryboard@ngpl.org	Trustee Apptd Annually Pres
Daniel Ramirez	N/A	N/A	N/A	N/A	3 years	4/30/2026	N/A	N/A	libraryboard@ngpl.org	Confirmed by Board
Larry Stuessy	N/A	N/A	N/A	N/A	2 years	4/30/2025	N/A	N/A	libraryboard@ngpl.org	

**VILLAGE OF NEW GLARUS  
2023 COMMITTEE APPOINTMENTS**

**APPEALS BOARD**

				Term	Expires				
Bill Bigler	PO Box 255	New Glarus	WI	53574	3 years	4/30/2024	558-5836	N/A	wbigler43@yahoo.com
Beth Luchsinger	318 9th Avenue	New Glarus	WI	53574	3 years	4/30/2024	206-7412	N/A	beth.luchsinger@yahoo.com
Peggy Blumer	513 4th Avenue	New Glarus	WI	53574	3 years	4/30/2026	212-7966	N/A	sctpsb69@gmail.com
Charles Phillipson, CHAIR	400 4th Avenue	New Glarus	WI	53574	3 years	4/30/2024	527-2038	N/A	cphillipson@newglarusvillage.com
Mike Ganshert	PO Box 871	New Glarus	WI	53574	3 years	4/30/2026	527-2701	558-0467	irishpiper3@gmail.com
Randy Kruse (1st Alternate)	219 Durst Rd	New Glarus	WI	53574	3 years	4/30/2026	527-2769	N/A	dvmkruse@gmail.com
Monika Pernot(2nd Alternate)	300 5th Ave,Box 798	New Glarus	WI	53574	3 years	4/30/2026	527-5028	N/A	rpernot@wekz.net

\*contacted, no response

**TREE BOARD**

Greg Thoemke, Chp	707 1st Street	New Glarus	WI	53574	2 years	4/30/2025	575-6888	N/A	gt4ng@yahoo.com
Forester (Paul Jennrich)	201 5th Street	New Glarus	WI	53574	indef.	N/A	527-5833	274-7600	treeguy@tds.net
PW Director (Joe Cockroft)	319 2nd St	New Glarus	WI	53574	indef.	N/A	558-5771	527-2097	pwdirector@newglarusvillage.com
Richard Irland, Citizen	419 13th Avenue	New Glarus	WI	53574	2 years	4/30/2025	214-0039	N/A	irlands@charter.net

**NG FIRE DIST (July - June)**

				Term	Expires				
John Ott, Chp (T NG)	N9096 Cty Trk O	New Glarus	WI	53574	3 years	2026	235-1204	N/A	johnburtonott@gmail.com
Gof Thomson	1100 2nd St.	New Glarus	WI	53574	2 years	2024	214-5642	N/A	thomson@newglarusvillage.com
Skyler Myers (T Perry)	194 Tyvand Rd	Blanchardville	WI	53574	3 years	2026	354-7576	N/A	smyers@thebankofnewglarus.bank
Brad Beal(V NG)	717 9th Ave	New Glarus	WI	53574	3 years	2024	527-2324	N/A	blbeal@tds.net
Dusten Hoesly (T NG)	N/A	New Glarus	WI	53574	3 years	2024	212-8362	N/A	hoesly63@gmail.com
Malcolm Austin (T Primrose)	461 Hwy. 92	Belleville	WI	53508	3 years	2025	712-1603	636-5279	malcolmaustin@msn.com
Ronald Erickson (T York)	W7307 Hwy 39	New Glarus	WI	53574	3 years	2025	527-2726	N/A	rrerickson@tds.net
Kent Anderson (Secretary, not apt.)	N/A	New Glarus	WI	53574	N/A	N/A	N/A	N/A	banderso@tds.net

One Citizen and 1 trustee  
(appointed by the bd)

**BOARD OF REVIEW**

Entire Village Board

**COMMUNITY DEVELOPMENT AUTHORITY**

Greg Thoemke (CHR)	707 1st Street	New Glarus	WI	53574	4 years	4/30/2027	575-6888	N/A	gt4ng@yahoo.com	[succeeding terms shall be 4 years
Dave Wyttenbach	400 Edelweiss	New Glarus	WI	53574	4 years	4/30/2027	527-5621	N/A	dwytttenbach@ub-t.com	for non-board members
David Staats	1013 1st St	New Glarus	WI	53574	4 years	4/30/2027	636-9666	N/A	hdhuntr@outlook.com	or board members run with term]
Carol Hassemmer	818 10th Avenue	New Glarus	WI	53574	4 years	4/30/2027	535-2225	N/A	chassem1@usa.net	
Mike Marty (VB rep)	618 14th Ave	New Glarus	WI	53574	N/A	4/30/2024	209-5284	N/A	mmarty@newglarusvillage.com	
Peggy Kruse (VB rep)	219 Durst Rd	New Glarus	WI	53574	N/A	4/30/2025	527-2769	444-9346	pkruise@newglarusvillage.com	
Mark Janowiak	207 2nd Street	New Glarus	WI	53574	4 years	4/30/2027	527-4220	N/A	prg@tds.net	2 shall be Board members

**ELECTION OFFICIALS-APPOINTED IN DECEMBER 2021**

							FC - First choice, rest are alternates			
Carol Thompson - FC	519 8th Avenue	New Glarus	WI	53574	2 year	12/31/2023	527-2799	N/A	ctom@tds.net	Unaffiliated
Dawn Johnson - FC	1006 Tower Circle	New Glarus	WI	53574	2 year	12/31/2023	527-4252	N/A	gladys9@tds.net	Unaffiliated
Jane Phillipson - FC	PO Box 82	New Glarus	WI	53574	2 year	12/31/2023	527-2038	608-214-2130	cjp@tds.net	Democratic
Kathryn Bartlett-Mulvihill - FC	913 2nd St	New Glarus	WI	53574	2 year	12/31/2023	443-7304	N/A	paeonias13@yahoo.com	Democratic
Barb Peterson - FC	W3290 Schaefer Rd	Belleville	WI	53508	2 year	12/31/2023	695-0605	N/A	barb@xweider.com	Republican
Carole Powers - FC	1013 1st St	New Glarus	WI	53574	2 year	12/31/2023	217-841-7096	N/A	cdpowers0027@gmail.com	Republican
Judy Renner - FC	1415 2nd St Unit B	New Glarus	WI	53574	2 year	12/31/2023	436-4904	N/A	mjranner@tds.net	Republican
Sue Hall	W4383 Schrade Rd	Monroe	WI	53566	2 year	12/31/2023	206-6916	N/A	shamrocksusie53566@yahoo.com	Republican
Lisa Bowers	N9221 Wild Oak Rd	Belleville	WI	53508	2 year	12/31/2023	212-7702	N/A	11bowers28@gmail.com	Republican
Shawn Zimmerman	W3076 St Hwy 92	Belleville	WI	53508	2 year	12/31/2023	577-9449	N/A	mamazimmerz@gmail.com	Republican
Deb Broge		Monroe	WI	53566	2 year	12/31/2023	289-3131	N/A	dabroge@yahoo.com	Republican
Shirley Lueschow	913 10th Avenue	New Glarus	WI	53574	2 year	12/31/2023	527-2049	N/A	slueschow@charter.net	Unaffiliated
Marilee Steffen	319 10th Avenue	New Glarus	WI	53574	2 year	12/31/2023	527-2407	N/A	marilees@tds.net	Unaffiliated
Stephanie Ganshert	306 Durst Rd.	New Glarus	WI	53574	2 year	12/31/2023	527-2701	N/A	ganshert2@tds.net	Unaffiliated
Beth Luchsinger	318 9th Avenue	New Glarus	WI	53574	2 year	12/31/2023	527-2089	608-206-7412	Beth.Luchsinger@yahoo.com	Unaffiliated
Kathy Brockman	306 Heidi Court	New Glarus	WI	53574	2 year	12/31/2023	214-3797	N/A	kkbrockman@gmail.com	Unaffiliated
Dorothy Peterson	113 Hillside Circle	New Glarus	WI	53574	2 year	12/31/2023	527-4307	N/A	minniedotp1@aol.com	Unaffiliated
Betsy Meter-Brooks	700 3rd Street	New Glarus	WI	53574	2 year	12/31/2023	527-4090	628-9796	elizabetsymeter@yahoo.com	Unaffiliated
Lisa Holthusen	319 Heidi Court	New Glarus	WI	53574	2 year	12/31/2023	608-333-1476	N/A	lisa.holthusen@gmail.com	Unaffiliated
Duane Bell	709 Haslen	New Glarus	WI	53574	2 year	12/31/2023	558-6226	N/A	duanebell@gmail.com	Unaffiliated

**VILLAGE OF NEW GLARUS**

**2023 COMMITTEE APPOINTMENTS**

Eileen Bell 709 Haslen	New Glarus	WI	53574	2 year	12/31/2023	558-6228	N/A	eileenbell75@gmail.com	Unaffiliated
Ann Lahey PO Box 291	New Glarus	WI	53574	2 year	12/31/2023	214-1114	N/A	aziltner@tds.net	Unaffiliated
Petra Streiff 319 2nd Ave	New Glarus	WI	53574	2 year	12/31/2023	527-4155	N/A	petrastreiff0@gmail.com	Unaffiliated



**VILLAGE OF NEW GLARUS****2023 COMMITTEE APPOINTMENTS**

Barb Anderson PO Box 1	New Glarus	WI	53574	2 year	12/31/2023	527-5146	558-8767	grammybarb@tds.net	Unaffiliated
Emily Kosmeder 801 3rd Street	New Glarus	WI	53574	2 year	12/31/2023	636-6226	N/A	emily.kufrin@gmail.com	Unaffiliated
Jamie Doeseckle 1200 1st St	New Glarus	WI	53574	2 year	12/31/2023	558-6950	N/A	jamie.doeseckle@gmail.com	Unaffiliated
Denise Anton Wright 418 6th Ave	New Glarus	WI	53574	2 year	12/31/2023	527-4917	608-636-4208	jdwright2@tds.net	Unaffiliated

**EMERGENCY GOV'T DIR**

					Home #		Work #		
Jeff Sturdevant	New Glarus	WI	53574		527-3680		558-5770	sturdevant@newglaruspolice.com	
ASSISTANT: Joe Cockroft	New Glarus	WI	53574		527-2097		558-5771	pwdirector@newglarusvillage.com	

**FORRESTER**

Paul Jennrich 201 5th Street	New Glarus	WI	53574		527-5833		274-7600	treeguy@tds.net	
------------------------------	------------	----	-------	--	----------	--	----------	-----------------	--

**PERSONNEL DIRECTOR**

Lauren Freeman 319 2nd Street	New Glarus	WI	53574				527-5971	Administrator@newglarusvillage.com	
-------------------------------	------------	----	-------	--	--	--	----------	------------------------------------	--

**WEED COMMISSIONER**

Mike Davis	New Glarus	WI	53574				558-8888	mmdavis@tds.net	
------------	------------	----	-------	--	--	--	----------	-----------------	--

**GREEN CTY DEVELOPMENT CORP.**

Lauren Freeman 319 2nd Street	New Glarus	WI	53574				527-5971	Administrator@newglarusvillage.com	
-------------------------------	------------	----	-------	--	--	--	----------	------------------------------------	--

**NEW GLARUS ECONOMIC DEVELOPMENT**

Lauren Freeman 319 2nd Street	New Glarus	WI	53574				527-5971	Administrator@newglarusvillage.com	
-------------------------------	------------	----	-------	--	--	--	----------	------------------------------------	--

**PARLIMENTARIAN**

Lauren Freeman 319 2nd Street	New Glarus	WI	53574				527-5971	Administrator@newglarusvillage.com	
-------------------------------	------------	----	-------	--	--	--	----------	------------------------------------	--

**PRESIDENT PRO-TEM**

Peg Kruse 219 Durst Rd	New Glarus	WI	53574				527-2769	pkruse@newglarusvillage.com	
------------------------	------------	----	-------	--	--	--	----------	-----------------------------	--

**CHAMBER REP.**

Lauren Freeman 319 2nd Street	New Glarus	WI	53574				527-5971	Administrator@newglarusvillage.com	
-------------------------------	------------	----	-------	--	--	--	----------	------------------------------------	--

**FRIENDS OF THE CHALET OF GOLDEN FLEECE REP**

Lauren Freeman 319 2nd Street	New Glarus	WI	53574				527-5971	Administrator@newglarusvillage.com	
-------------------------------	------------	----	-------	--	--	--	----------	------------------------------------	--

**TID JOINT REVIEW BOARD REP**

Roger Truttman 518 4th Avenue	New Glarus	WI	53574				212-6785	rtruttman@newglarusvillage.com	
Dave Wyttenbach, Citizen Rep									